

Swing Type Torsion Gates

English Translation

Specification & Drawings

for International Search Report

on Patentability

T e r a M a t s u

Contents

	Volume
• International Search Report (Japanese)	3 pages
• Specification & claims (English)	14 pages
• Drawings (English)	12 pages

特許協力条約

発信人 日本国特許庁 (国際調査機関)



代理人 大木健一 様 あて名 〒113-0034 日本国東京都文京区湯島二丁目15番1-205
--

PCT
 国際調査機関の見解書
 (法施行規則第40条の2)
 [PCT規則43の2.1]

発送日
 (日.月.年) 08.12.2015

出願人又は代理人 の書類記号 XT0215W001	今後の手続きについては、下記2を参照すること。	
国際出願番号 PCT/J P 2015/077164	国際出願日 (日.月.年) 25.09.2015	優先日 (日.月.年)
国際特許分類 (IPC) Int.Cl. E02B7/40(2006.01)i		
出願人 (氏名又は名称) 寺田 博		

1. この見解書は次の内容を含む。

- 第I欄 見解の基礎
- 第II欄 優先権
- 第III欄 新規性、進歩性又は産業上の利用可能性についての見解の不作成
- 第IV欄 発明の単一性の欠如
- 第V欄 PCT規則43の2.1(a)(i)に規定する新規性、進歩性又は産業上の利用可能性についての見解、それを裏付けるための文献及び説明
- 第VI欄 ある種の引用文献
- 第VII欄 国際出願の不備
- 第VIII欄 国際出願に対する意見

2. 今後の手続き
 国際予備審査の請求がされた場合は、出願人がこの国際調査機関とは異なる国際予備審査機関を選択し、かつ、その国際予備審査機関がPCT規則66.1の2(b)の規定に基づいて国際調査機関の見解書を国際予備審査機関の見解書とみなさない旨を国際事務局に通知していた場合を除いて、この見解書は国際予備審査機関の最初の見解書とみなされる。

この見解書が上記のように国際予備審査機関の見解書とみなされる場合、様式PCT/ISA/220を送付した日から3月又は優先日から22月のうちいずれか遅く満了する期限が経過するまでに、出願人は国際予備審査機関に、適当な場合は補正書とともに、答弁書を提出することができる。

さらなる選択肢は、様式PCT/ISA/220を参照すること。

見解書を作成した日 25.11.2015	
名称及びあて先 日本国特許庁 (ISA/J P) 郵便番号100-8915 東京都千代田区霞が関三丁目4番3号	特許庁審査官 (権限のある職員) 神尾 寧 電話番号 03-3581-1101 内線 3241

第 I 欄 見解の基礎

1. 言語に関し、この見解書は以下のものに基づき作成した。

- 出願時の言語による国際出願
 出願時の言語から国際調査のための言語である _____ 語に翻訳された、この国際出願の翻訳文 (PCT規則12.3(a)及び23.1(b))

2. この見解書は、PCT規則 91 の規定により国際調査機関が認めた又は国際調査機関に通知された明らかな誤りの訂正を考慮して作成した (PCT規則 43 の 2.1(b))。

3. この国際出願で開示されたヌクレオチド又はアミノ酸配列に関して、提出された以下の配列表に基づき見解書を作成した。

- a. 提出手段 紙形式
 電子形式
- b. 提出時期 出願時の国際出願に含まれていたもの
 この国際出願と共に電子形式により提出されたもの
 出願後に、調査のために、この国際調査機関に提出されたもの

4. さらに、複数の版の配列表又は配列表の写しを提出した場合、出願後に提出した配列の写し若しくは追加して提出した配列の写しが、出願時に提出した配列と同一である旨又は出願時の開示を超える事項を含まない旨の陳述書の提出があった。

5. 補足意見：

第V欄 新規性、進歩性又は産業上の利用可能性についてのPCT規則43の2.1(a)(i)に定める見解、それを裏付ける文献及び説明

1. 見解

新規性 (N)	請求項 請求項	1-5 _____	有 無
進歩性 (I S)	請求項 請求項	1-5 _____	有 無
産業上の利用可能性 (I A)	請求項 請求項	1-5 _____	有 無

2. 文献及び説明

文献1: JP 2003-239263 A (三菱重工業株式会社) 2003.08.27, 全文 (ファミリーなし)

文献2: JP 2009-84883 A (日本車輛製造株式会社) 2009.04.23, 全文 (ファミリーなし)

文献3: JP 2013-2250 A (日立造船株式会社) 2013.01.07, 全文 (ファミリーなし)

文献4: JP 62-90420 A (豊国工業株式会社) 1987.04.24, 全文 (ファミリーなし)

請求項1-5に係る発明は、国際調査報告に引用されたいずれの文献にも記載されておらず、当業者にとって自明なものでもない。

Description

SLUICE GATE

Technical Field

【 0 0 0 1 】

The present invention relates to a sluice gate installed in a sluice for water flow or ships. The gate accommodates high tide water, tsunami, high water (reverse flow from a main river to a tributary stream), ocean waves, flood wood flow etc.

Background Art

【 0 0 0 2 】

A large scale gate provided against high tide water, tsunami etc. is well known.

【 0 0 0 3 】

A flap gate whose gate leaf is a thin shell closed section (torsion structure) is one of gate types used for sluice gates. Although the gate leaf is, in general, supported by a foundation ground via axle type supports and rotates around the axles, some gate leaf is supported directly by a water bottom concrete structure and this supporting system is simple in structure and very advantageous in cost (Non-Patent Document 1, Patent Document 1).

【 0 0 0 4 】

Fig. 1 is a section which shows an example of the flap gate which is supported by the concrete structure.

【 0 0 0 5 】

Reference numeral 1 denotes a gate leaf (solid line, in a closed state), 2 denotes the gate leaf (dotted line, in an opened state), 3 denotes a rotation center of the gate leaf 1, 4 denotes a concrete structure, and 5 denotes a wood seat.

【 0 0 0 6 】

The wood seat 5 is fixed on the gate leaf 1 and 2.

【 0 0 0 7 】

When the gate is not in use, the gate leaf (in an open position) 2 is stored horizontally underwater as the dotted line shows. When in use, the gate leaf (in its open state) 2 rotates around the rotation center 2, rises up, and moves to the position of the gate leaf (in its closed state) 1 of the solid line and is supported by the concrete structure 4 via the wood seat 5.

【 0 0 0 8 】

A swing movement type is the well known type of gate open and closure procedure and the structural advantage of flap gate described at 【 0 0 0 3 】 can be used by this type.

【 0 0 0 9 】

Fig. 2 shows the swing movement type of a open and closure type tidal sluice gate. Fig. 2 shows the left half of the tidal sluice gate viewed from a sea side. Fig. 2a is a plan. Fig. 2b is an elevation.

【 0 0 1 0 】

6 denotes a gate leaf in a completely closed state. 7 denotes a gate leaf in a completely opened state. The sluice gate of Fig. 2 is in either state 6 or 7.

【 0 0 1 1 】

8 denotes a swing center of the gate leaf 6, 9 denotes a storage pier of the gate leaf 7, and 10 denotes a center line of the tidal sluice gate.

【 0 0 1 2 】

The gate leaf 7 in the completely opened state is tied up at the storage pier 9. When in use, the hydraulic gate door (in its open state) 7 swings around the swing center 8 and moves to the position of the gate leaf (in its closed state) 6.

Prior Art Documents

Patent Documents

【 0 0 1 3 】

Patent Document 1: JP S50-16334A

Patent Document 2: WO 2014/037987 A1

Non-Patent Documents

【 0 0 1 4 】

Non-Patent Document 1: Hiroshi Terata, Noriaki Shigenaga, Torsion type flap gate for docks, Mitsubishi Heavy Industries, Ltd. TECHNICAL REVIEW June, 1980

Disclosure of the Invention

Problems to be Solved by the Invention

【 0 0 1 5 】

Although the torsion structure has an overwhelming advantage in cost, its application to a gate has been limited to a flap gate that is fixed on the foundation ground via axle type supports. This invention enables application of the torsion structure to, for instance, a tidal gate that moves in a swing motion and makes the overwhelming advantage of torsion structure even higher. The application is also applicable to a super large tidal gate having a structure support span between 200 to 600 m and more.

【 0 0 1 6 】

This invention shows resolutions to the following problems, contributing to implementation of a swing movement type tidal gate of the torsion structure.

Problem 1: Gate leaf stability at gate mounting on a water bottom

Problem 2: Gate leaf motion at gate open and closure operation

Problem 3: Gate leaf operation with the help of tidal flow

Problem 4: Reaction force and impact force on a gate leaf bottom support seat

【 0 0 1 7 】

Problem 1: Gate leaf stability at gate mounting on a water bottom

When in use, the gate leaf tied up at the storage pier moves to the gate totally closed position by a swing motion. The gate leaf is in the state of floating on water during swing movement and provides a stability function which follows a stability theory of ship. The gate leaf at the completely closed position mounts on a water bottom after exhausted its buoyancy by water filling into its buoyancy tank. A stability function of the gate leaf in a bottom mounting state may disappear and the gate leaf would turn over on the water bottom if it happened.

【 0 0 1 8 】

Problem 2: Gate leaf motion at gate open and closure operation

Opening and closing in wild weather ocean waves is one of important operation conditions of a tidal sluice gate in-service. As the gate leaf in swing movement is in the state of floating on water, it pendulums just like a ship in ocean waves. Main elements of the pendulum is rolling, pitching and dipping. It is not preferable to restrict all the elements by the swing center since the restriction brings periodic constraint forces which is not favorable for structural strength.

【 0 0 1 9 】

Problem 3: Gate leaf operation with the help of tidal flow

It is inevitable that gate leaf operation is made in the state of tide difference existence on both sides (sea side and port side) of the gate leaf. Gate leaf operation would not have any problems when the difference is so small that gate leaf control may be possible by on-board thruster machines (side thruster) or tug-boats etc. Completely closing operation will be made with the help of tide elevation on the sea side after the gate leaf is mounted on a water bottom within the gate controllable range of swing angle when gate closing operation is carried out with the tide difference much more than the difference previously mentioned. And, opening operation with the help of tide level on port side is possible. Problems on the gate leaf operation with the help of tidal flow are (3.1) Gate leaf lateral inclination and (3.2) Impact energy. Each problem is explained in the following.

【 0 0 2 0 】

(3.1) : Gate leaf lateral inclination

The gate leaf is in the state of water bottom mounting during open and closure operation with the help of tide difference and friction force works on the mounting surface as the gate leaf removes. The gate leaf yields big lateral inclination due to rotation moment composed by the tide difference and the friction force whose directions are cross each other.

The gate leaf mounted on a water bottom may turn over because of stability function disappearance.

【 0 0 2 1 】

(3.2): Impact energy

Completely closing operation is made with the help of tide elevation on the sea side after the gate leaf is mounted on a water bottom within the gate controllable range of swing angle when gate closing operation is carried out with the tide difference which is so big that gate leaf control may be impossible by on-board thruster machines (side thruster) or operation tug-boats etc. The gate leaf starts to remove pushed by the tide level on sea side, arrives at the completely closed position with gradually increasing speed and hits a water bottom concrete structure. The impact energy is the kinetic energy accumulated in the gate leaf while the gate leaf is removing from the bottom mounting position to the completely closed position and there may be a possibility of damaging the gate leaf and the water bottom concrete structure if the hit force grows big with too much the kinetic energy.

【 0 0 2 2 】

Problem 4: Reaction force and impact force on a gate leaf bottom support seat

When gate leaf closing operation is made in tidal flow a bottom support seat on the gate leaf hits a water bottom concrete structure and impact force caused by the gate leaf rotation initiation works on the seat besides reaction force of gate leaf inertia force. It is necessary that damage of the seat due to the reaction force and the impact force are averted..

Means of Solving the Problems

【 0 0 2 3 】

A sluice gate which is equipped with a swing center support mechanism, a friction shoe/shoes and a gate leaf bottom support seat and operation steps in tidal flow are proposed to implement a opening/closing gate which is equipped with costly advantageous torsion structure and removes in swing motion. The support mechanism is rotation free and moving constraint in three axes directions and subject to pulling-up force. The friction shoe dissipate tidal energy so that gate damage may be averted. The gate bottom support seat provides flexibility and high strength together so that it may decrease the impact power and endure the reaction force. Appropriate dissipation of tidal energy will be carried out by a friction force strength selection in the operation steps.

【 0 0 2 4 】

Alternatively, a swing center support mechanism may be rotation free in two axes directions and moving constraint in three axes directions.

Brief Description of Drawings

【 0 0 2 5 】

Fig. 1 illustrates an example of a torsion structure flap gate supported by a water bottom

concrete structure.

Fig. 2 is an explanatory drawing of a swing movement type.

Fig. 3 is an example of tidal sluice gate planning data.

Fig. 4 is an overall view of Embodiment 1 and is an embodiment of a swing movement type hydraulic gate door.

Fig. 5 illustrates a float tank arrangement and gate leaf acting forces of Fig. 4.

Fig. 6 is a detail drawing of operation tank of Fig. 5 and illustrates partition of a buoyancy and a backup buoyancy.

Fig. 7 is calculated results of Fig. 5 and Fig. 6.

Fig. 8 an explanatory drawing of a swing center mechanism in Embodiment 1.

Fig. 9 is a detail drawing of a friction shoe in Embodiment 1.

Fig. 10 an explanatory drawing of the friction shoe and is an external force acting drawing before inclination.

Fig. 11 an explanatory drawing of the friction shoe and is an external force acting drawing after inclination.

Fig. 12 is an example of friction shoe bottom fashions.

Fig. 13 is external moment (torsion moment) working on gate leaf unit width.

Fig. 14 is a control limit of a side thruster.

Fig. 15 is a plan of installation site where a gate leaf of Embodiment 1 is operated with the help of tidal flow.

Fig. 16 illustrates steps of the operation in tidal flow of Embodiment 1.

Fig. 17 is an explanatory drawing of a swing center support mechanism of Embodiment 2.

Fig. 18 is an explanatory drawing of a bottom support seat of Embodiment 3.

Embodiments of the Invention

【 0 0 2 6 】

Fig. 3 is an example of tidal sluice gate planning data.

Embodiment 1

【 0 0 2 7 】

Fig. 4 is an example based upon the data of Fig. 3 and illustrates a swing movement type tidal sluice gate. Fig. 4 illustrates the left half of the tidal sluice gate viewed from a sea side. Fig. 4a is a plan. Fig. 4b is an elevation.

【 0 0 2 8 】

6 denotes a gate leaf in a completely closed state. 7 denotes a gate leaf in a completely opened state. The sluice gate of Fig. 2 is in either state 6 or 7.

【 0 0 2 9 】

8 denotes a swing center of the gate leaf 6, 9 denotes a storage pier of the gate leaf 7, 10 denotes a center line of the tidal sluice gate, 11 denotes a swing center support mechanism, 12 denotes side thrusters, and 13 denotes a friction shoe.

【 0 0 3 0 】

The gate leaf 7 in the completely opened state is tied up at the storage pier 9. When in use, the gate leaf (in its open state) 7 moves by swing motion around the swing center 8 to the position of the gate leaf (in its closed state) 6 and mounts on a water bottom after exhausted its buoyancy.

【 0 0 3 1 】

Fig. 5 is the gate leaf 7 in swinging motion of Fig. 4 and illustrates float tank arrangement and acting forces of the gate leaf 7. Fig. 6 is a detail drawing of the operation tank on Fig. 5 and illustrates partition of a buoyancy and a backup buoyancy.

【 0 0 3 2 】

The tank arrangement of Fig. 5 includes three kind of tanks which are an operation tank, a balance tank and a upright tank and the acting force of Fig. 5 includes 5 kind of forces which are operation buoyancy, balance buoyancy, upright buoyancy, gate leaf weight W and pulling-up force S and the gate leaf 7 of Fig. 4 floats on water by the operation tank backup buoyancy of Fig. 6. Role of each tank is as following.

Upright tank: Maintenance of gate leaf uprightness by coupled with the pulling-up force S

Balance tank: Downsizing the operation tank by balanced with majority of the gate leaf weight

Operation tank: Downwelling/surfacing operation of the gate leaf by filling/draining water in it

【 0 0 3 3 】

Fig. 7 is a calculation result of the acting forces and the tank capacity which are shown on Fig. 5 and 6. The calculation result is an estimate including assumptions that steel displacement is negligible, the buoyancy works upon each float tank center, free surface effect of the tanks is negligible, and specific weight of water equals 1. Center height of the balance tank and the upright tank approximately coincide with the gate leaf gravity height. As the both tanks always submerge, their backup buoyancy is zero and the gate leaf in swing motion floats on water surface only with the backup buoyancy of the operation tank accordingly. Water of the same quantity as the backup buoyancy (1126 tf) is poured into the operation tank after gate leaf 7 of Fig. 4 arrives at the position of the gate leaf 6 in completely closed state, then the tank buoyancy in Fig. 7 — the pulling-up force $S = 9000$ tf which consorts with the gate leaf weight W . If the gate leaf 7 is softly pushed down in this instant of time a free end of the gate leaf 7 starts to sink, the friction shoe 13 on Fig. 4 arrives at a water bottom (the bottom mounting), and the gate leaf 7 is fit in the position of the gate leaf 6 on Fig. 4. A load of the friction shoe 13 in this state is zero. The load of friction shoe 13 becomes 1074 tf when additional water quantity poured into the operation tank arrives at the tank buoyancy (1074 tf). As overturn moment of the gate leaf 6 at this time is linear to the shoe load and upright moment is linear to the pulling-up moment S , a safety factor becomes about 2.7 and overturn of the gate leaf 6 will be avoided (corresponding to previously mentioned "Problem 1: Gate leaf stability at gate mounting on a water bottom").

【 0 0 3 4 】

The swing center support mechanism 11 of Fig. 4 is a support point fixed on a water bottom, whose support condition is rotation free and moving constraint in three axes directions and always subject to pulling-up force. Fig. 8 illustrates an example which satisfies this support condition. Fig. 8a is an elevation of the swing center mechanism 11. Fig. 8A is AA section of Fig. 8a. Fig. 8B is BB section of Fig. 8A. Fig. 8C is CC section of Fig. 8B. Fig. 8D is DD section of Fig. 8C. Fig. 8E is EE section (metals) of Fig. 8D. The gate end support key of Fig. 8a is the functional heart of the swing center support mechanism 11 and Fig. 8A thru Fig. 8E show details of the gate end support key. A section of the key of Fig. 8B is an across shape which is shown on Fig. 8D and the upper half of it composes a key spherical head which is shown on Fig. 8B. A key support is fixed to a anchorage embedded in a sea bottom concrete that is shown on Fig. 8E, the lower half of the key is inserted into the key support that is shown on Fig. 8B, and they are joined together with wire clips. The key spherical head fixed to a sea bottom as described above is covered by a spherical seat fitted on the gate leaf side as shown on Fig. 8B. The inside of the spherical seat and the outside of the key spherical head work as bearing surfaces and they facilitate load carrying function and sliding function. The lower half of the spherical seat is fixed by welding to the gate leaf side and the upper half of it is removable fitting of bolts out of a maintenance need. The lower half of the spherical seat is usually subject to the pulling-up force S which works upward.

【 0 0 3 5 】

Support condition of the swing center support mechanism 11 on Fig. 4 is rotation free and moving constraint in three axes directions. On the other hand, pendulum of the gate leaf during its swing motion in ocean waves is rolling, pitching, dipping etc. The pendulum motion of the gate leaf has a rotation element and a removing element at a support point of the swing center support mechanism 11. Although the removing element is restricted by the support point of the three axes direction moving constraint, the rotation element is not restricted by the support point of the three axes direction rotation free and impact of the gate leaf pendulum on its structural strength will be remarkably mitigated (corresponding to previously mentioned "Problem 2: Gate leaf motion at gate open and closure operation").

【 0 0 3 6 】

Fig. 9 is a detail of the friction shoe 13 on Fig. 4. Fig. 9a is an enlarged view of the gate leaf (solid line, in a closed state) 6. Fig. 9A is AA section of Fig. 9a. Fig. 9B is BB section of Fig. 9A.

【 0 0 3 7 】

Reference numeral 6 denotes a gate leaf, 8 denotes a swing center, 13 denotes a friction shoe, 14 denotes an upper of the friction shoe 13, 15 denotes a wear-resistant material covering a tread of the friction shoe 13, 16 denotes a bottom support seat (water sealing) or the gate leaf 6, 17 denotes a tip of the wear-resistant material 15, and 18 denotes an arc radius of the tip 17.

【 0 0 3 8 】

The tip 17 of the wear-resistant material 15 covering a tread of the friction shoe 13 which is shown on Fig. 9A composes an arc of the radius 18.

【 0 0 3 9 】

Fig. 10 and 11 illustrate a gate leaf on which a couple consisting of the tide difference Δh and the shoe friction force is working and Fig. 10 is the gate leaf before inclination emerges and Fig. 11 is after inclination emerges. The shoe reaction force and the shoe friction force (= Shoe reaction force \times Friction coefficient) of Fig. 10 work on the point right below the shoe load working at the gravity center and these of Fig. 11 have removed to the position of the radius 18. A horizontal component and a vertical component of the tide difference Δh work on the gate leaf due to the inclination of β° . Consequently, the vertical component of the tide difference Δh is added to the shoe reaction force and the shoe friction force. The gate leaf stays at the inclination angle of β° in the state that the inclination moment composed of a coupling which consists of the horizontal component of the tide difference Δh and the shoe friction force and a coupling which consists of the vertical component of the tide difference Δh and the shoe reaction force consorts with the upright moment composed of a coupling which consists of the shoe load and the shoe reaction force and a coupling which consists of the pulling-up force S and the upright buoyancy. In addition, the inclination would not emerge when the friction coefficient is small (for instance, the friction coefficient <0.3) because a coupling of the shoe load and the shoe reaction force is predominantly grater than a coupling of the shoe friction force and the horizontal component of the tide difference Δh , and the gate leaf removes up to the completely closed position keeping upright state (corresponding to previously mentioned "Problem (3.1): Gate leaf lateral inclination").

【 0 0 4 0 】

There can be many shoe tread forms with which the gate leaf can remove keeping upright state or small inclination angle β° . Fig. 12 illustrates the examples. The form combination items of the examples are both ends or one end of a bend side, vertical or inclined of a end wall form and a circular arc or a free curve of a bent form, and a common appearance of all the combinations is the tip 17 of convex curvature form.

【 0 0 4 1 】

Tidal flows in the world excluding special geographies as seen at Seto Inland Sea etc. are between 1.0 and 3.0 Kt (\doteq 0.5 and 1.5 m/s) in general. The gate leaf closing operation in tidal flow, in short, the operation in tidal flow is made at flow speed of this level.

【 0 0 4 2 】

Fig. 13 illustrates external moments (torsion moments) working on unit width of the gate leaf during a high tide and at a collision during the operation in tidal flow. They are results of calculation based on the data of Fig. 3. The external load at a collision is inertia force of the gate leaf and its virtual mass and the magnitude of inertia force has been so

determined that strain energy resulted in the gate leaf may equal strain energy accumulated in the gate leaf during a high tide. Suppose the strain energy during a high tide corresponds to yield stress, the corresponding external moment during a collision will be the structural limit of the gate leaf and it is calculated on the moment that the gate leaf tip speed is between 1 and 1.5 m/s and the impact force on the gate leaf bottom support seat is 321 tf/m. The width of calculated speed is due to difference of the virtual mass considered.

【 0 0 4 3 】

It is estimated that there may be a case where a reduction of tidal flow energy becomes necessary to avoid the gate damage during the operation in tidal flow. Its means are the friction force of friction shoe, a side thruster, a tug-boat etc. The friction force will be 107 ft in the case that the shoe load is 1074 tf and the friction coefficient is 0.1. Fig. 14 is an example of control limit of gate leaf mounting type side thrusters and shows control limits of keeping the gate leaf in rest state by flow velocity and tide difference.

【 0 0 4 4 】

Fig. 15 is a plan of a gate leaf installation site and illustrates a bottom mounting position, a totally closed position, a bottom mounting angle θ_c , a direction of tidal flow, and a swing center for the operation in tidal flow.

【 0 0 4 5 】

Fig. 16 is a gate leaf closing step of the operation in tidal flow. As the friction force of Step 2 = the friction load \times the friction coefficient and the shoe load = 1074 — the operation buoyancy, the intensity of friction force is selected by a proper selection of the operation buoyancy. The operation buoyancy selection is made according to a selection chart. The selection chart will be prepared according to results of a hydraulic model experiment and a prototype verification test carried out at every project. The tidal flow level, the gate leaf collision velocity and the energy dissipation level are shown at 【 0 0 4 1 】 thru 【 0 0 4 3 】 where kinetic energy of the gate leaf which arrives at the totally closed position is maintained at lower than the limit value by following the closing operation steps of Fig. 16 and gate leaf damage and destructive impact force eruption are avoided due to the kinetic energy transfer to the strain energy there (corresponding to previously mentioned "Problem (3.2): Impact energy").

【 0 0 4 6 】

The step 3 of Fig. 16 indicates a gate leaf move by tidal flow force. Although the tidal flow force is being dissipated by the friction force and conveys the gate leaf up to the completely closed position where the gate leaf keeps its velocity less than or equal to the limited value, a gate leaf tip speed sensing during the operation and, if necessary, a limit speed keeping by side thrusters etc. are required since the friction force = the shoe load \times the friction coefficient and the friction coefficient may vary across the ages. And after the gate levitation prevent apparatus is set on at the step 8, appropriate buoyancy is given to the gate leaf by air filling into the operation tank in order to provide for a open operation by tidal flow in

reverse direction due to tide level lowering.

Embodiment 2

【 0 0 4 7 】

Fig. 17 is another example of the swing center support mechanism which is shown on Fig. 8 and while Fig. 8 shows an example which satisfies the support condition of rotation free and moving constraint in three axes directions, Fig. 17 shows an example which satisfies the support condition of rotation free in two axes directions and moving constraint in three axes directions.

【 0 0 4 8 】

Fig. 17a is an elevation of the swing center support mechanism 11. Fig. 17F is FF section of Fig. 17a. Fig. 17G is GG section of Fig. 17F. Fig 17H is HH section of Fig. 17G. The end rotation axle of Fig 17a is a mechanism which is added to Fig. 8a and Fig. 17F thru 17H shows details of the end rotation axle. For a detail of the end support key of Fig. 17a, the details of end support key shown on Fig. 8A thru 8E are applicable. As shown on Fig 17F, the round axle is fixed on the hydraulic gate support pier, the long axle hole is fixed on the gate leaf side and the round axle is set by being inserted into the long axle hole. Fig. 17G shows the long axle hole fixed on the gate leaf side and the round axle set by being inserted into the long axle hole. A center line of the round axle coincides with the swing center. Fig. 17H shows the state of the round axle which is fixed on the hydraulic gate support pier is set by being inserted into the long axle hole which is fixed on the gate leaf. For reference, the longer diameter of the long axle hole coincides with direction by which pitching motion of the gate leaf around the end support mechanism is allowed and the diameter in the direction of restricting gate leaf rolling which is at right angle motion to the pitching is just a bit bigger than the round axle diameter so that the impact load and hydraulic load working on the gate leaf during completely closed term may be supported by the end support key and the end support bracket.

【 0 0 4 9 】

The gate leaf during swing motion floats on water only by the backup buoyancy of the operation tank which is shown on Fig. 6. Water of the same quantity as the backup buoyancy (1126 tf) is poured into the operation tank after gate leaf 7 of Fig. 4 arrives at the position of the gate leaf 6 in completely closed state, then the tank buoyancy — the pulling-up force $S = 9000$ tf which consorts with the gate leaf weight W . If the gate leaf 7 is softly pushed down in this instant of time a free end of the gate leaf 7 starts to sink, the friction shoe 13 on Fig. 4 arrives at a water bottom (the bottom mounting), and the gate leaf 7 is fit in the position of the gate leaf 6 on Fig. 4. A load of the friction shoe 13 in this state is zero. The load of friction shoe 13 becomes 1074 tf when additional water quantity poured into the operation tank arrives at the tank buoyancy (1074 tf). Although overturn moment of the gate leaf 6 at this time is linear to the shoe load, overturn of the gate leaf 6 will be avoided

without the aid of the upright moment of pulling-up force S since the overturn is restricted by the round axle of Fig. 17 (corresponding to previously mentioned "Problem 1: Gate leaf stability at gate mounting on a water bottom").

【 0 0 5 0 】

Pendulum of the gate leaf during its swing motion in ocean waves is rolling, pitching, dipping etc. The pendulum motion of the gate leaf has a rotation element and a removing element at a support point of the swing center support mechanism 11. Although the removing element is restricted by the support point of the three axes direction moving constraint, the rotation element of the pitching is not restricted by the support point of the two axes direction rotation free and a part of the dipping is transferred to a pitching motion. Although big rolling is restricted by the round axle of Fig. 17 whose impact on structural strength may slightly increase, the impact can be mitigated by an appropriate consideration since restriction force of the rolling is small (corresponding to previously mentioned "Problem 2: Gate leaf motion at gate open and closure operation").

【 0 0 5 1 】

Although an inclination moment works on the gate leaf due to a coupling of the horizontal component of the tide difference Δh and the shoe friction force and a coupling of the vertical component of the tide difference Δh and the shoe reaction force when the gate leaf is operated with the aid of the tide difference Δh , the gate leaf removes up to the completely closed position keeping upright state since a big inclination is restricted by the round axle of Fig. 17 (corresponding to previously mentioned "Problem (3.1): Gate leaf lateral inclination").

Embodiment 3

【 0 0 5 2 】

Fig. 18 shows an example of the bottom support seat which provides both flexibility and high strength. Fig. 18a illustrates relative position of the bottom support seat and the gate leaf bottom. Fig. 18A is the detail A of Fig. 18a. Fig. 18B is BB section of Fig. 18A

【 0 0 5 3 】

A gate leaf portion which hits the concrete structure of the port side sea bottom is the bottom support seat when the gate leaf is operated with the aid of the tide difference Δh and the support seat is subject to a impact power created by a start of gate leaf section rotation at once after the hitting and the reaction force associated with transformation of kinetic energy to strain energy. The reaction force correspond to the inertia force and start by zero and arrives at its maximum value when the energy transformation completes. The support seat needs flexibility as well as high strength owing to accept forces of different kinds. Fig. 18A illustrates the state that a still material like steel etc. is embedded in a flexible material like rubber etc. Fig. 18B illustrates the state that the flexible material and the stiff material continue in a gate leaf length direction. The support seat keeps the flexibility due to

this construction. When a flexible material is subject a compression, the inside flexible material surrounded by stiff material approaches to a state of three axial stress (hydrostatic stress). Material has a tendency to get higher yield point when its stress distribution approaches to a status of the hydrostatic stress. For instance, this phenomena is a back ground of a roller and a rail whose contact surface stress is bigger than their braking strength. The impact power created by a start of gate leaf section rotation is mitigated by the flexibility of the initial stage of the hitting and the big reaction force of the inertia force is absorbed by the high strength after compressed (corresponding to previously mentioned "Problem 4: Reaction force and impact force on a gate leaf bottom support seat").

Explanation of Reference Numerals

【 0 0 5 4 】

- 1: gate leaf (solid line, in a completely closed state) (flap)
- 2: gate leaf (dotted line, in a completely opened state) (flap)
- 3: rotation center (flap)
- 4: concrete structure (flap)
- 5: wood seat (flap)
- 6: gate leaf (solid line, in a completely closed state) (swing)
- 7: gate leaf (dotted line, in a completely opened state) (swing)
- 8: swing center
- 9: storage pier (swing)
- 10: center line of the tidal sluice gate (swing)
- 11: swing center support mechanism
- 12: side thruster
- 13: friction shoe
- 14: upper (friction shoe)
- 15: wear-resistant material (friction shoe)
- 16: bottom support seat (sealing)
- 17: tip (wear-resistant material)
- 18: arc radius (tip)

CLAIMS

【請求項 1】

流水や船舶の水路を横切る方向に設けられ、全開時は格納位置に係留され、全閉時は浮上状態でスイング活動により全閉位置に移動する扉体を備える水門において、前記扉体は、水底に固定された支持点を持ち、前記支持点の支持条件が 3 軸方向回転自由 E つ移動拘束であることを特徴とする水門。

【請求項 2】

流水や船舶の水路を横切る方向に設けられ、全開時は格納位置に係留され、全閉時は浮上状態でスイング活動により全閉位置に移動する扉体を備える水門において、前記扉体は、水底と前記扉体の上部に中心軸を共有する固定された支持点を持ち、前記支持点の支持条件が 2 軸方向回転自由且つ 3 軸方向移動拘束であることを特徴とする水門。

【請求項 3】

水門稼働中において、前記支持点には引き力が作用することを特徴とする請求項 1 又は請求項 2 記載の水門。

【請求項 4】

前記扉体の底部に摩擦靴を備え、前記摩擦靴の靴底先端部が凸形湾曲形状であることを特徴とする請求項 1 又は請求項 2 記載の水門。

【請求項 5】

前記扉体が陸側海底の構造に接触する箇所に設けられる底部支持座を備え、前記底部支持座は柔軟材の中に剛材が埋め込まれ、柔軟且つ高強度に構成されていることを特徴とする請求項 1 又は請求項 2 記載の水門。

Abstract

A sluice gate which is equipped with a swing center support mechanism, a friction shoe/shoes and a gate leaf bottom support seat and operation steps in tidal flow are proposed to implement a opening/closing gate which is equipped with costly advantageous torsion structure and removes in swing motion. The support mechanism is rotation free and moving constraint in three axes directions and subject to pulling-up force. The friction shoe dissipate tidal energy so that gate damage may be averted. The gate bottom support seat provides flexibility and high strength together so that it may decrease the impact power and endure the reaction force. Appropriate dissipation of tidal energy will be carried out by a friction force strength selection in the operation steps.

[Fig. 1]

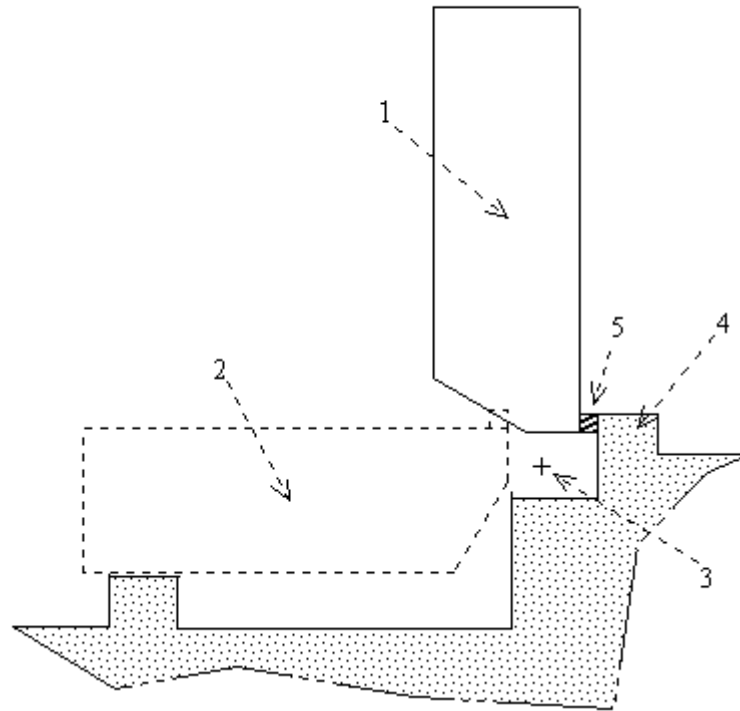

[Fig. 2]

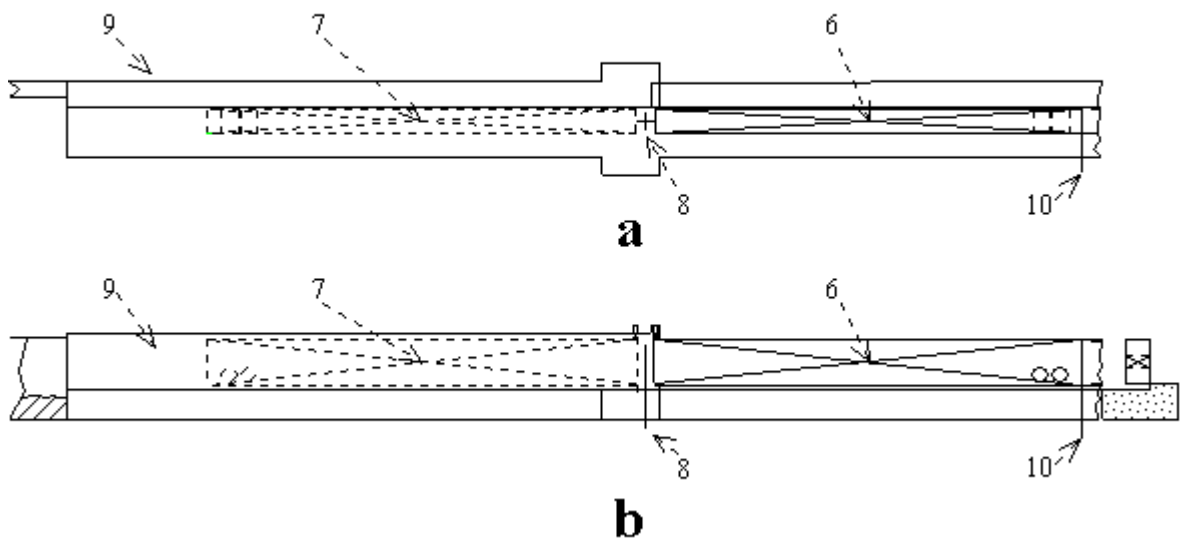
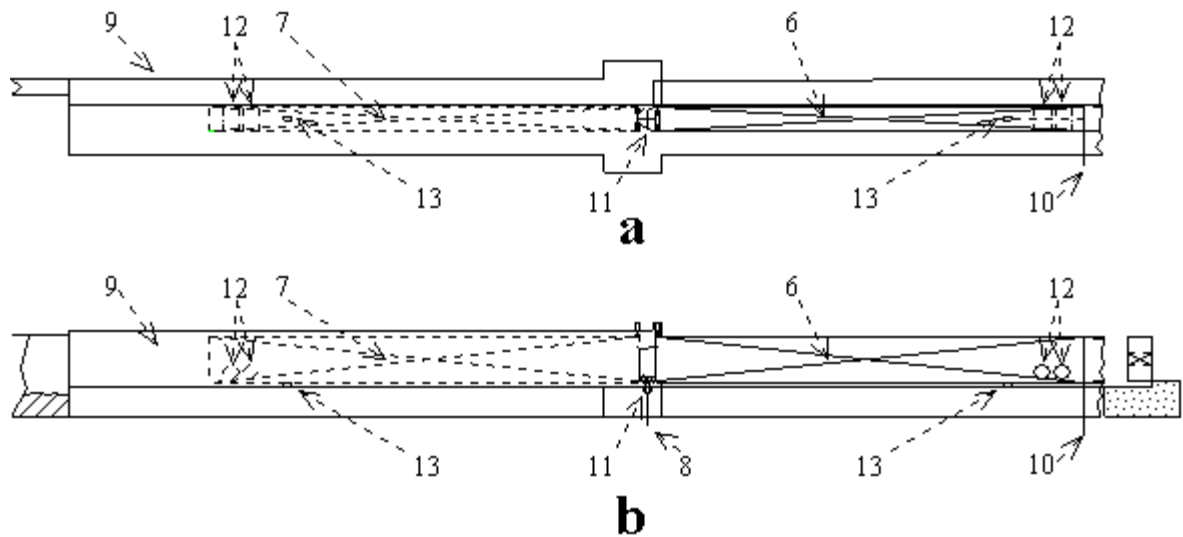
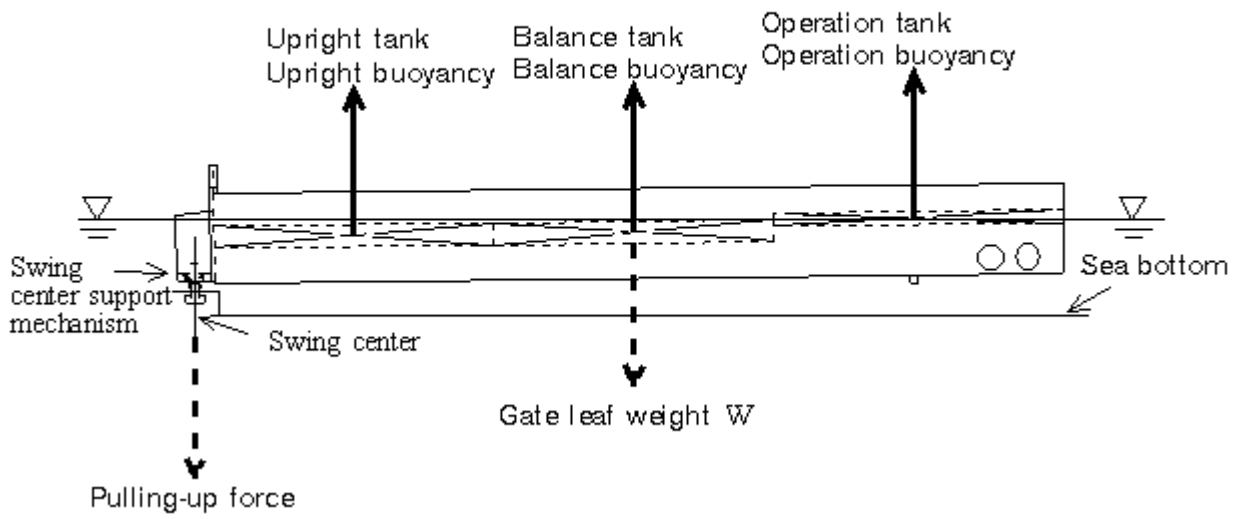

Fig 3				
Item		Data	Unit	Note
Gate dimension	Span	450	m	○○ Port Design A (Super Large Tidal Gate) (excluding steel weight.)
	Height	23		
	Width	12.5		
Hydraulic condition	Site depth	16	tf	
	Tide def.	5		
	Freeboard	2		
Steel weight (rough estimation)	Gate leaf	18000	tf	
	Embedded part	1500		
	Machine	500		
	Total	20000		

[Fig. 4]



[Fig. 5]



[Fig. 6]

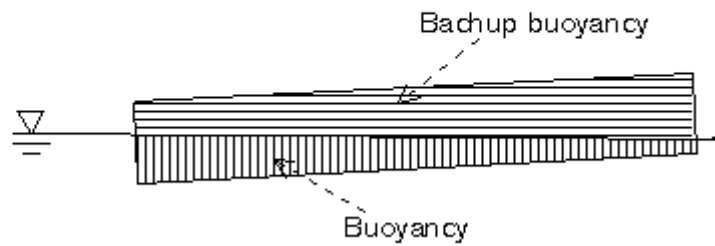
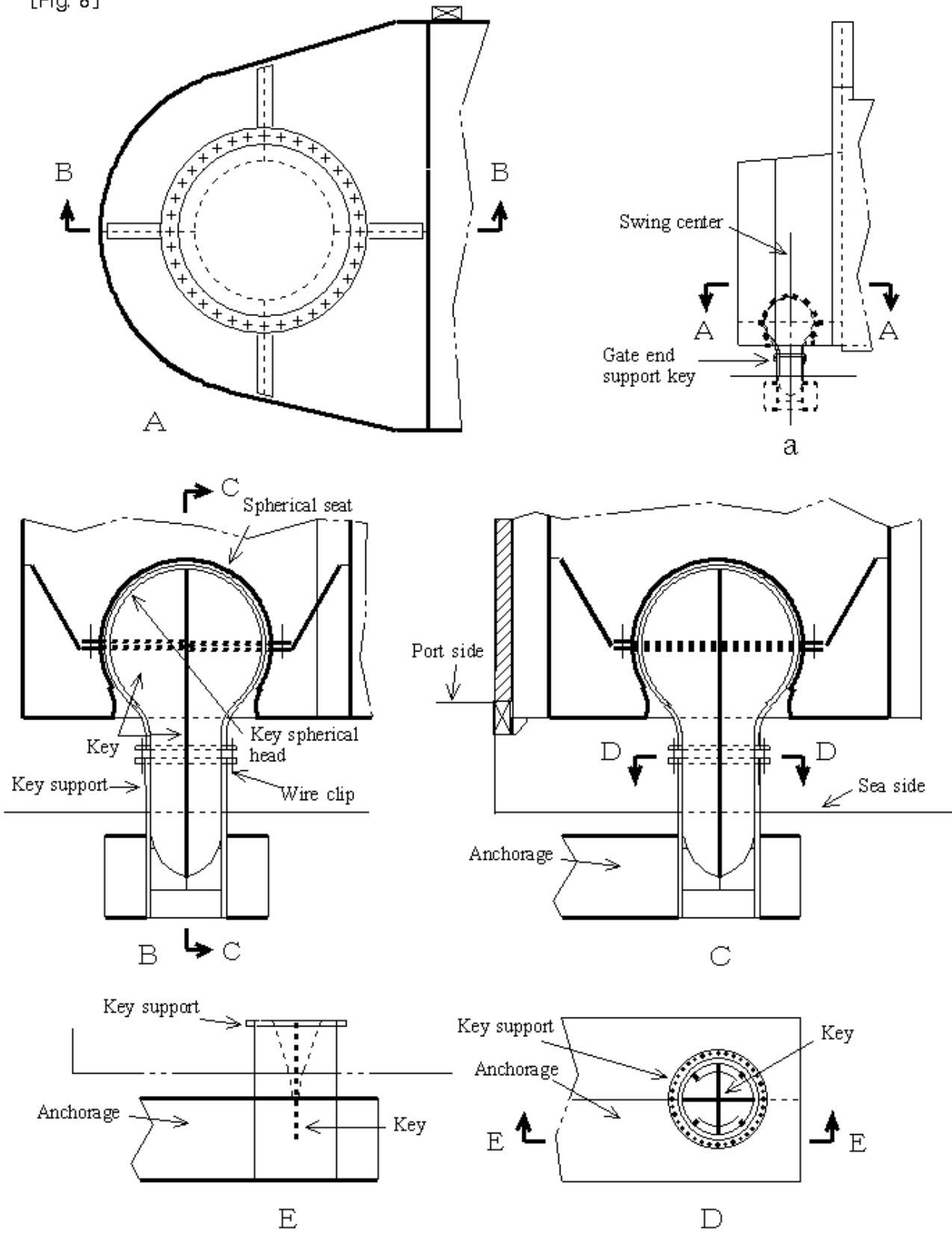

Fig 7

Calculation item		Gate leaf regio					Total
		Upright tank	Blance tank	Operation tank	Swing center	Gravity center	
Tank capacity(m3)		5408	5408	2200	-	-	13016
Acting force	Backup buoyancy(tf)	0	0	1126	-	-	1126
	Buoyancy(tf)	5408	5408	1074	-	-	9000
	Pullingup force S(tf)	-	-	-	2890	-	9000
	Gate leaf weight W (tf)	-	-	-	-	9000	9000

[Fig. 8]



[Fig. 9]

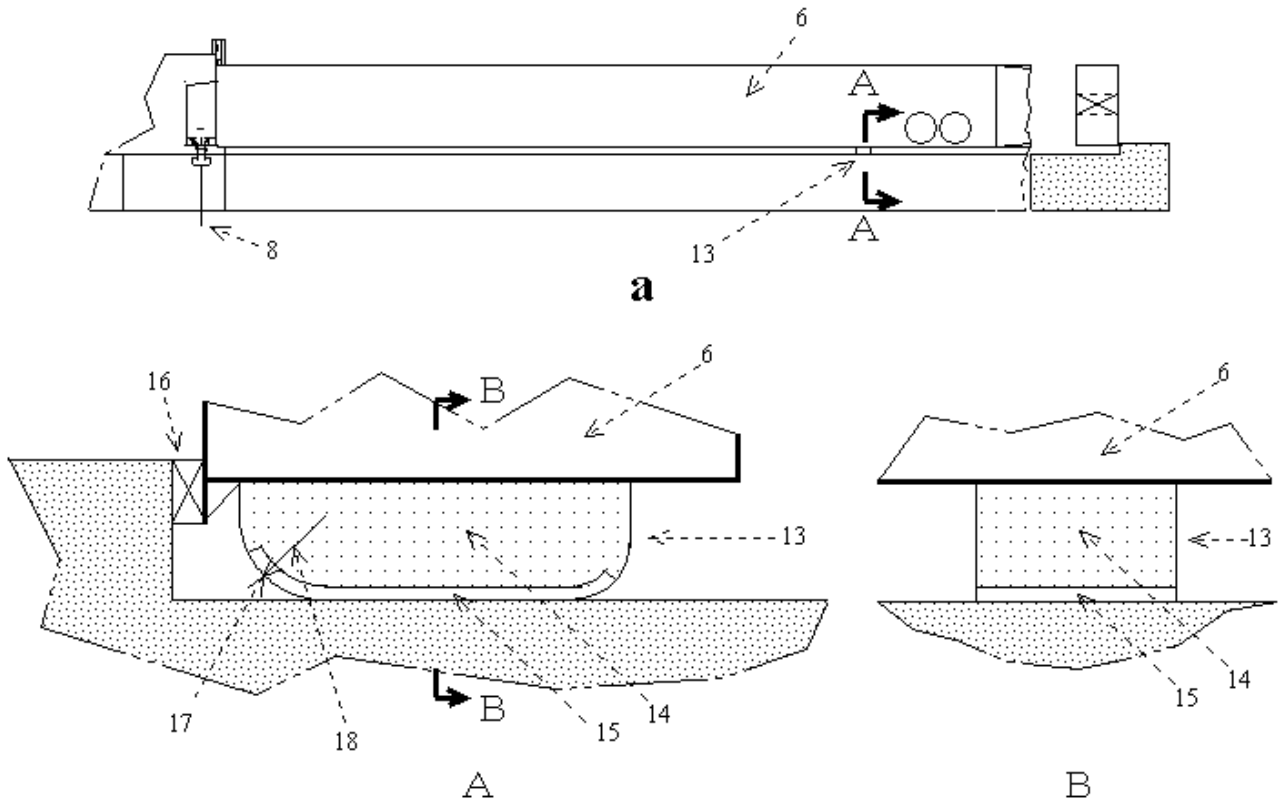

[Fig. 10]

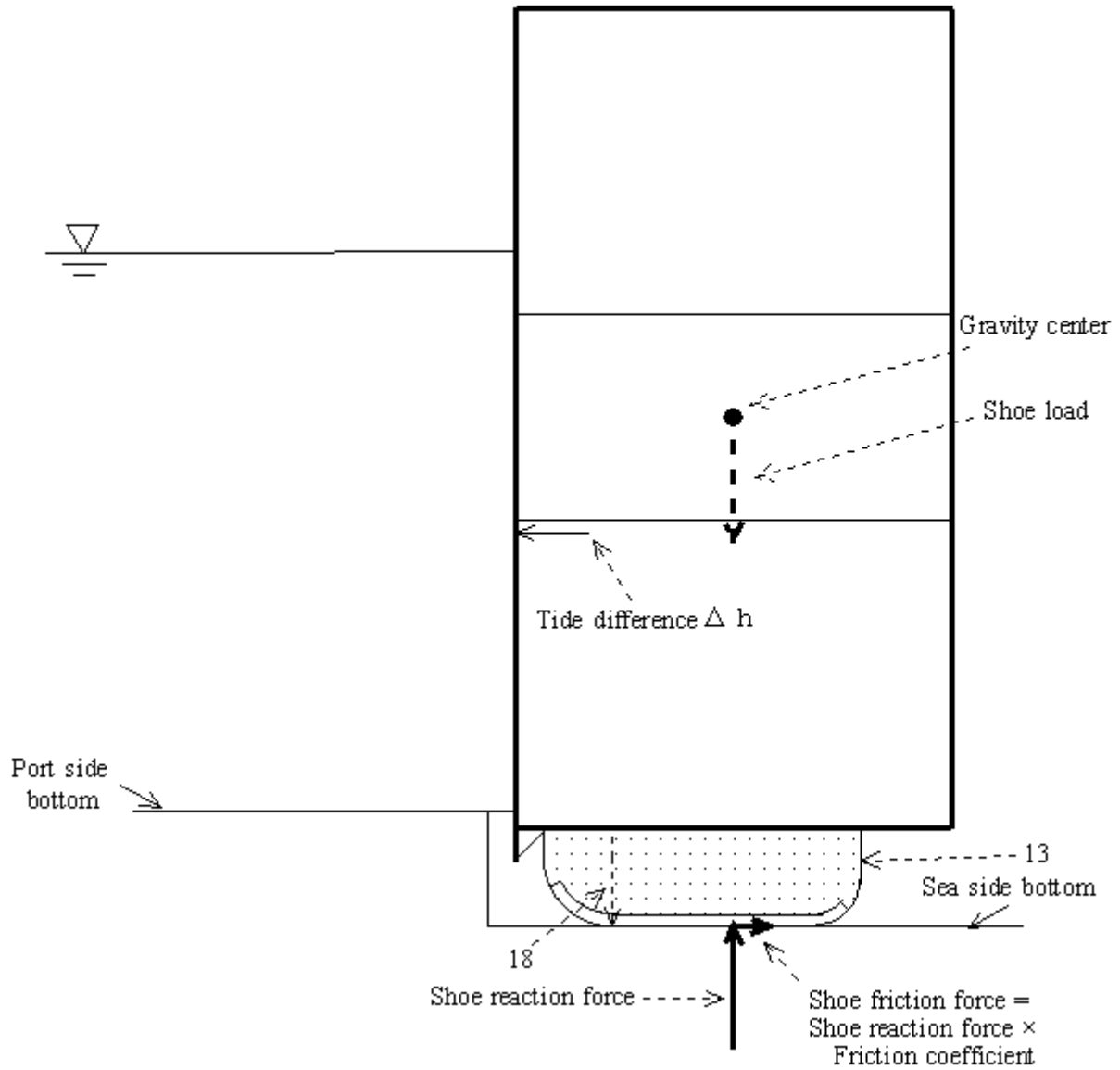

[Fig. 11]

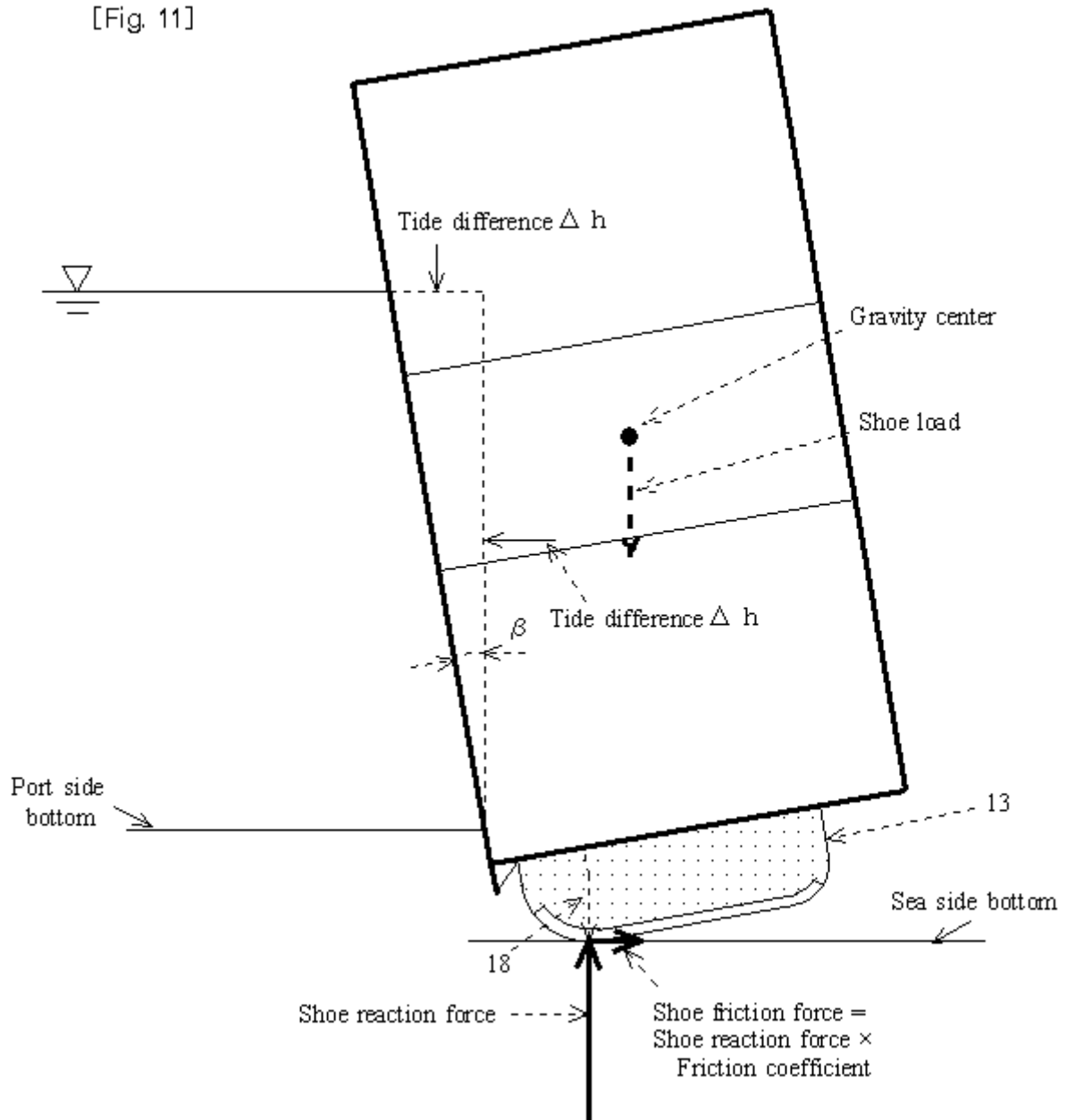

[Fig. 12]

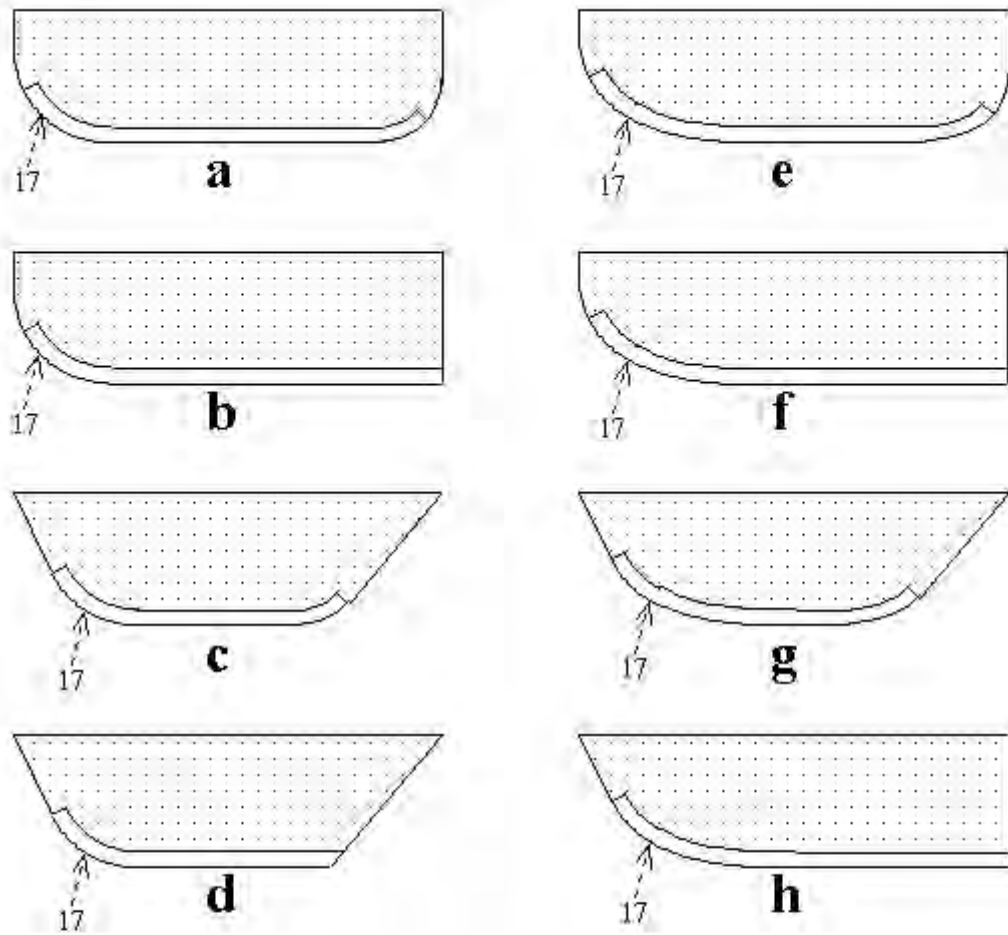

Combination items for shoe tread form		Figure mark							
		a	b	c	d	e	f	g	h
Bent side	Both ends	○		○		○		○	
	One end		○		○		○		○
End wall form	Vertical	○	○			○	○		
	Inclined			○	○			○	○
Bent form	Circular arc	○	○	○	○				
	Free curve					○	○	○	○

Shoe tread form combination

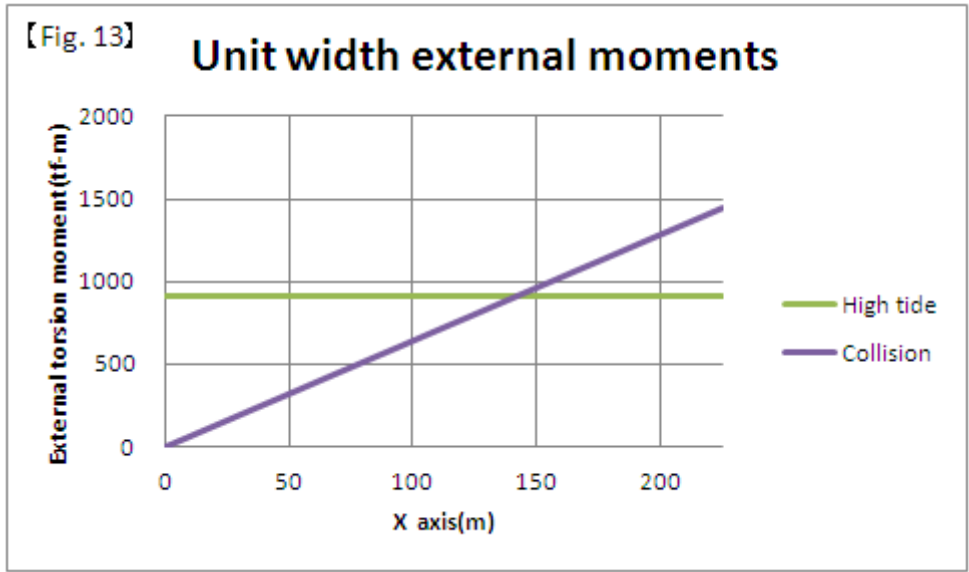

[Fig 14]

Side thruster					Control limit	
Case No.	Thrust tf	Kw	Number of unit	Total thrust	V. cm/s	Tide dif. cm
1	40	2680	1	40	66.0	2.2
2	50	3350	1	50	73.8	2.8
3	60	4000	1	60	80.8	3.3
4	40	2680	2	80	93.3	4.4
5	50	3350	2	100	104.3	5.6
6	60	4000	2	120	114.3	6.7

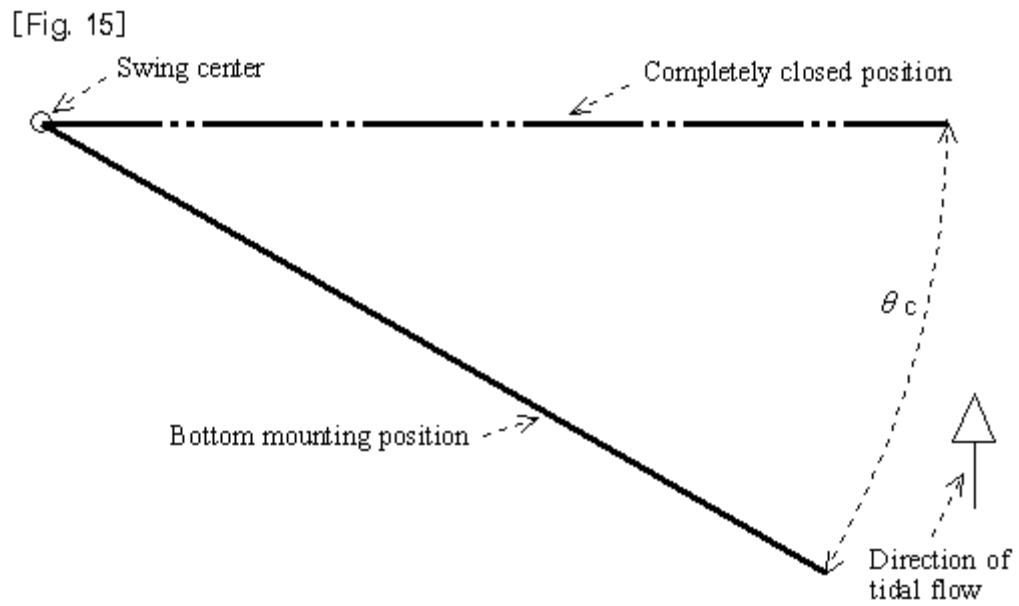

【 Fig. 16】

Gate leaf closing operation steps

1. Travel to a bottom mounting position with help of a side thruster
2. Bottom mounting after operation buoyancy is set
3. Travel with help of tidal flow (Gate body tip speed < allowable limit)
4. Arrival at a gate completely closed position
5. Confirming a gate body tip position
6. Exhausting operation buoyancy
7. Side thruster shutdown
8. Setting gate levitation prevent apparatus on

[Fig. 17]

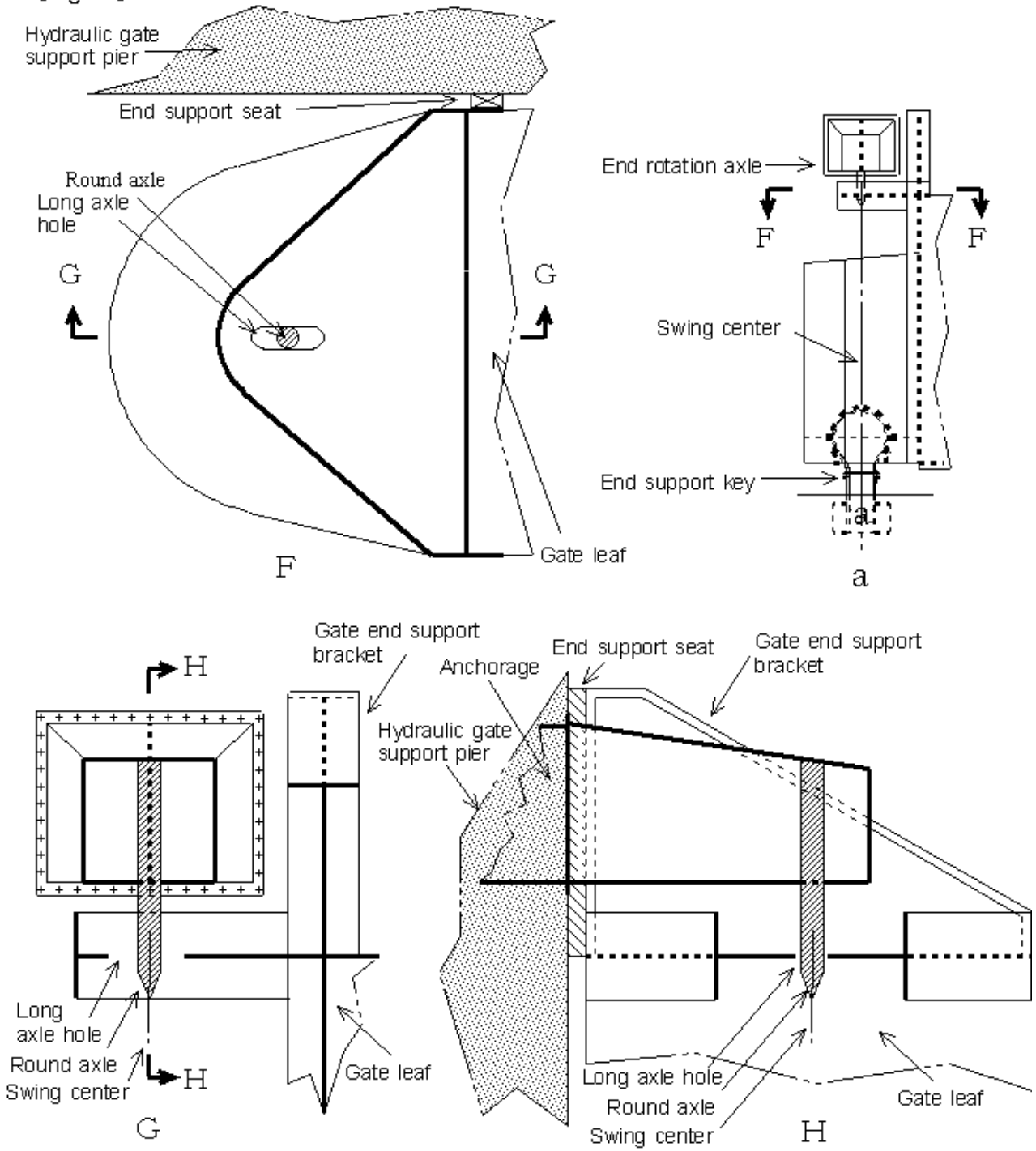

[Fig. 18]

